

BBYC Haul out - How to measure your boat and set up the cradle in 2025.

Why this is important

It takes nearly two 'man-hours' for volunteers to start the tractor, collect the trolley, position it under your cradle, load the cradle, secure the cradle, attach your bow rope, move the cradle to the top of the ramp, chock the trolley, disconnect from trolley, unwrap lowering cable, reverse tractor to far end of Yard, reconnect to trolley, prepare trolley's tracking, lower trolley to the correct depth and await your part – guiding your boat into the cradle.

If you have not adjusted the cradle correctly, your boat will not fit safely.

The underlined steps will have to be repeated in addition to the time spent by the Haul out team readjusting your cradle on the ramp, using their best assessment of the correct measurements which **you** should have known in the first place.

If a Waiheke Ferry passes, we pause operations to avoid your boat being rocked in the cradle by the ferry's wake.

Delays accumulate and eat into the time when we can haul as once the tide is full, it will turn.

Other boats after you may miss out as there is not enough water for them to haul.

Be accurate in your measurements. When adjusting, you will need someone to help holding your tape measure and (depending on the cradle) maybe two ladders to reach the correct height for measuring.

What you need to know:

- The distance between the forward and rear horns of the Cradle: **A**
- The draft of your boat (bottom of keel to waterline): **D**
- The height of the gunwale above the bottom of the keel, abeam the mast: **H**

What you do next

- Measure the beam of the boat at the Mast: **BF**. This is important and not easy if the mast is in the way. Do your realistic best. Next time your boat is in the Yard, use a plumb-line to the ground, each side, on a calm day, mark the asphalt, and measure the distance. Don't lose your measurement! See note about tumblehome below.
- Measure the beam at the aft cradle arms: **SF** (*distance A, aft of the mast*).
Note: some boats have tumblehome (where the hull grows narrower above the waterline). You must include the extra width caused by tumblehome, or the boat will not slide into the cradle.
- **Keep these measurements safely for next year with any adjustments noted with experience.**

To set up the cradle:

- Wrap brightly coloured tape around the forward starboard horn at the level of the waterline **D**. (*Haul out Foreman must be able to see tape from 30 metres away*)
- Set the forward arms apart at the height **H** by the distance **BF**. Make sure the arms are symmetrical about the centre line of the cradle.
- Set the rear arms apart at the height **H** by the distance **SF**, adding 200 mm to your calculation.

**Make sure the arms have been opened an equal amount on each side of the cradle.
The arms must not be lop-sided at different angles.**

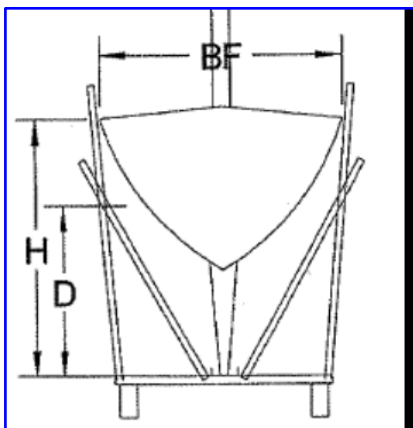

Cradle side

Cradle when

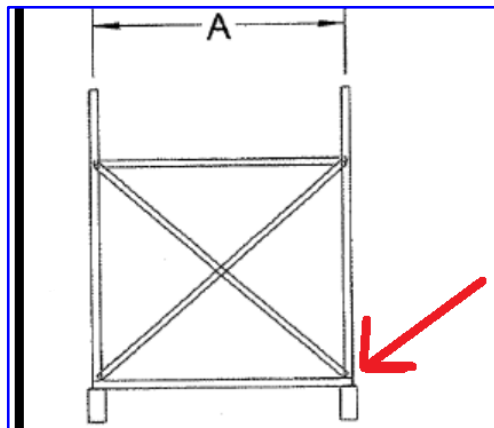

seen from front viewed from the

Note: the front of the cradle (the bows) are on the right. Arrow indicates the approximate position (on each side) where Horn Lines attach. This will vary, as cradles vary. The Yard Foreman will advise you.

Done correctly, it's a piece of cake. Your boat should sit in the cradle with the mast between the front horns.